

Socket Weld Couplings

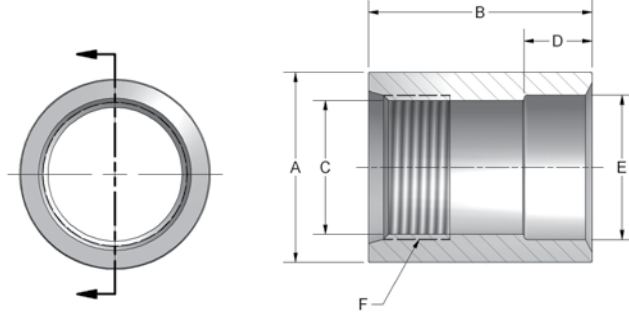

- AISI 1020 Carbon Steel
- 316L Stainless Steel
- Includes individual thread identification marking
- Additional thread sizes and configurations available

SAE TO SOCKET WELD PIPE COUPLING							
CARBON STEEL PART NO.	STAINLESS STEEL PART NO.	A	B	C	D	E	F SAE UN-2B
820-8	820-8-SS	1.25	1.63	.689	.560	.855	*3/4-16
820-12	820-12-SS	1.50	2.06	.981	.560	1.062	1 1/16-12
820-16	820-16-SS	1.75	2.06	1.231	.630	1.328	1 5/16-12
820-20	820-20-SS	2.25	2.06	1.544	.690	1.672	1 5/8-12
820-24	820-24-SS	2.75	2.20	1.794	.750	1.922	1 7/8-12
820-32	820-32-SS	3.25	2.50	2.419	.875	2.406	2 1/2-12
820-40	820-40-SS	3.75	3.00	2.919	1.000	2.910	3-12
820-48	820-48-SS	4.40	3.00	3.419	1.25	3.550	3 1/2-12
820-64	820-64-SS	5.25	3.25	4.419	1.250	4.55	4 1/2-12

*UNF-2B

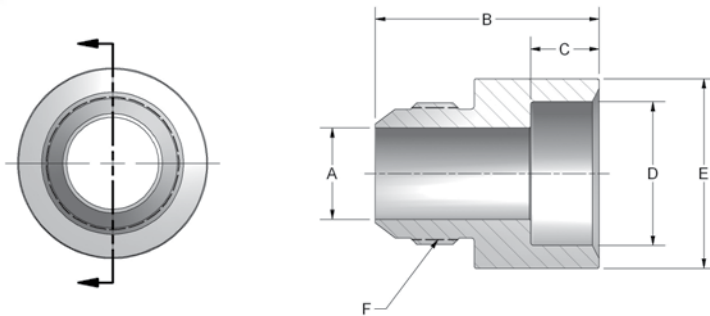

- AISI 1020 Carbon Steel
- 316L Stainless Steel
- Includes individual thread identification marking
- Additional thread sizes and configurations available

SOCKET WELD PIPE TO MALE JIC COUPLING							
CARBON STEEL PART NO.	STAINLESS STEEL PART NO.	A	B	C	D	E	F THREAD
840-8	840-8-SS	.391	1.63	.560	.855	1.25	*3/4-16
840-12	840-12-SS	.609	1.89	.560	1.062	1.50	1 1/16-12
840-16	840-16-SS	.844	2.06	.630	1.328	1.75	1 5/16-12
840-20	840-20-SS	1.078	2.06	.690	1.672	2.25	1 5/8-12
840-24	840-24-SS	1.312	2.20	.750	1.922	2.75	1 7/8-12
840-32	840-32-SS	1.781	2.50	.875	2.406	3.25	2 1/2-12

*UNF-2A